

WIRE ROPE ISOLATORS: **NAVAL HALF HELICAL** series **NHH** DEFINITION

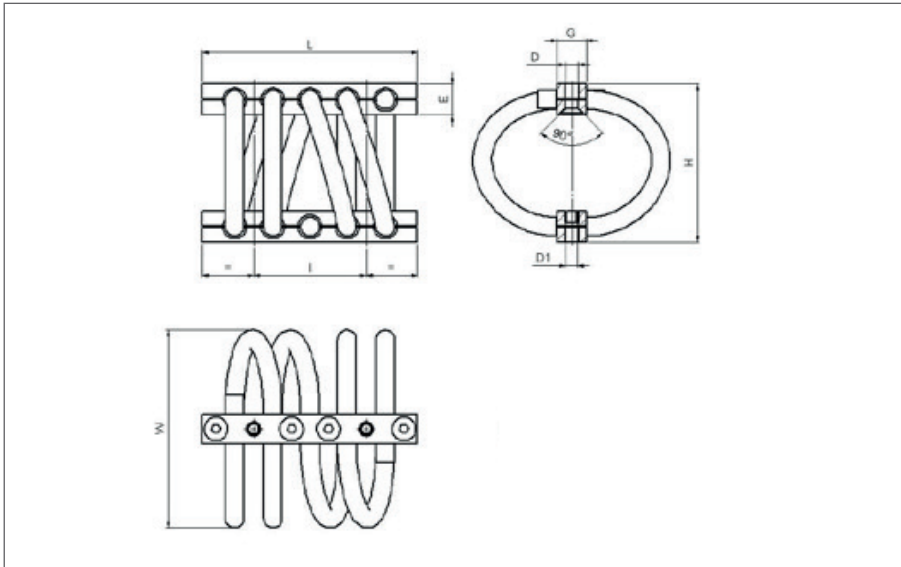

- All metal multidirectional anti-vibration/ shock mounts.
- Exceptional reliability and long life.
- High damping.
- No ageing - Corrosion resistant.
- Unequalled temperaturerange: -180°C +300°C.
- Non-magnetic.
- Low residual acceleration.
- Easy 3 points mounting.

Dimensions are in mm. For reference only.

SERIE
Materials and finishes (meets RoHS requirements)
NHH
Cable: stainless steel AISI 316
Retainer bars: Aluminium Alloy / SurTec
(bar 2 in AISI 316 ZS, both bars ZSS)
Screws / Inserts: alloy steel, zinc plate
Other materials on request

DIMENSION									
type*	H	W	L	I	E	G	D/D1	Mass (kg)	
020	124	143	120	63	16.5	20	8.5/8	0.8	
045	124	146	120	63	16.5	20	8.5/8	1	
070	137	156	156	83.3	20.5	25	8.5/8	1.4	
110	160	200	218	114.3	31.5	30	13.5/12	3.5	
180	159	178	218	114.3	38	40	13.5/12	4.5	
320	159	178	218	114.3	38	40	13.5/12	4.7	
400	159	178	218	114.3	38	40	13.5/12	5	
450	216	245	314	164	52.5	50	20/18	12	
800	216	251	314	164	52.5	50	20/18	14	

INTERFACE			
fixtures holes D / D1	Top Bar*		
	2 through holes ø D mm	2 through holes ø D mm countersunk 90°	2 inserts M D1
Lower Bar*			
2 through holes ø Dmm	TM2	not standard	not standard
2 through holes ø D mm countersunk 90°	CM	CM2	not standard
2 inserts M D1	IM	CIM	IM2

*Type corresponds to nominal static loading

EXAMPLE
NHH180-CIM

N	H	H	1	8	0	-	C	I	M
---	---	---	---	---	---	---	---	---	---

PREFIX:
'naval
half helical' mount
from the
NHH series

MODEL: 180
height: 159mm
width: 178mm
mass: 4,5kg

SUFFIX: CIM
2 through holes ø Dmm
in upper bar*
2 inserts M12 in
lower bar*



*Top & lower are used for description purposes; mounts can be mounted upside down

WIRE ROPE ISOLATORS: **NAVAL HALF HELICAL** series NHH

PERFORMANCES

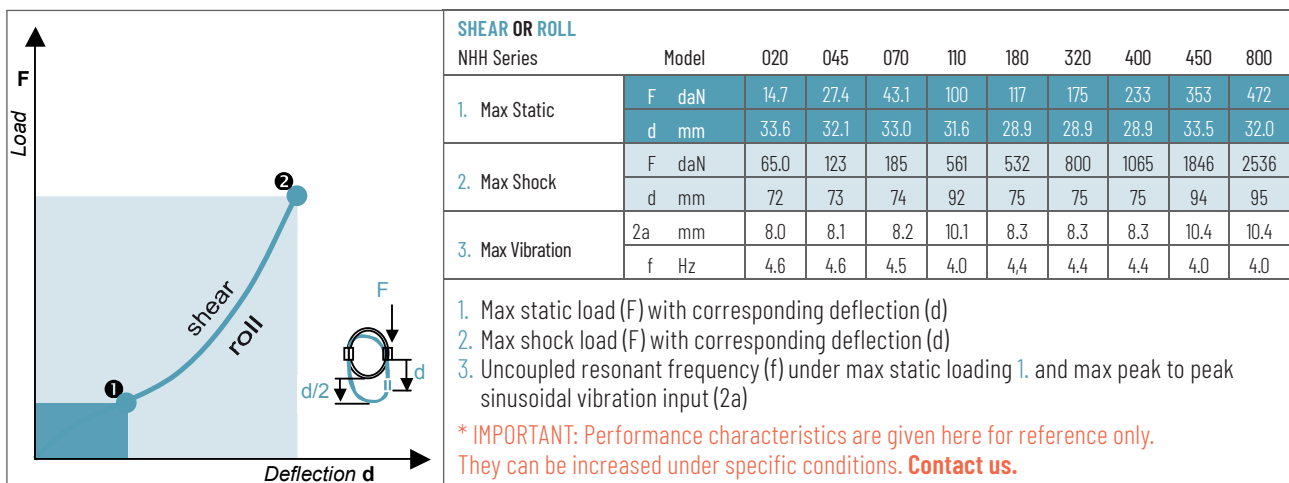
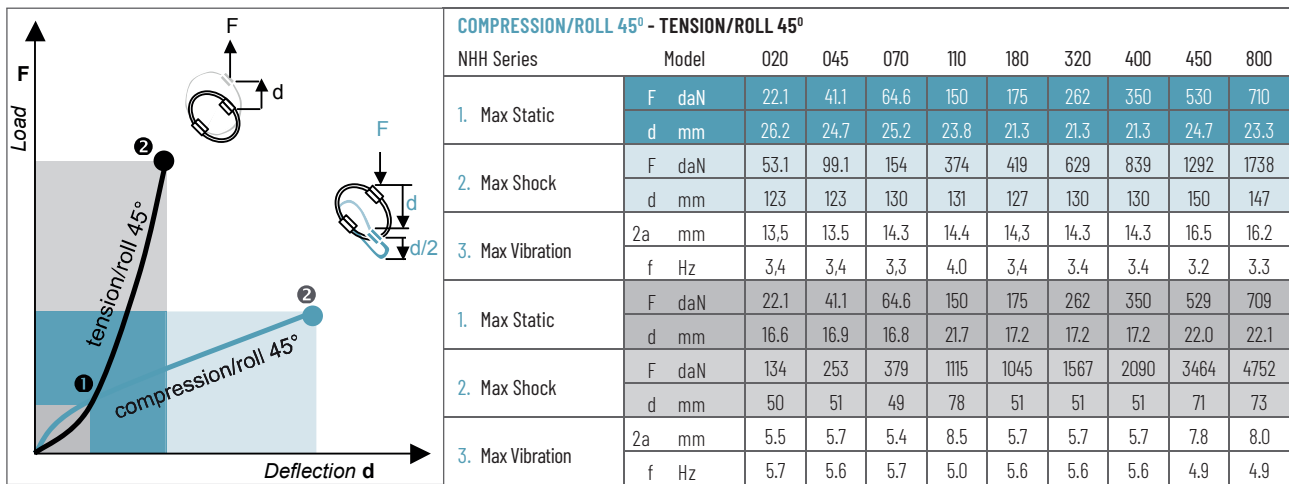
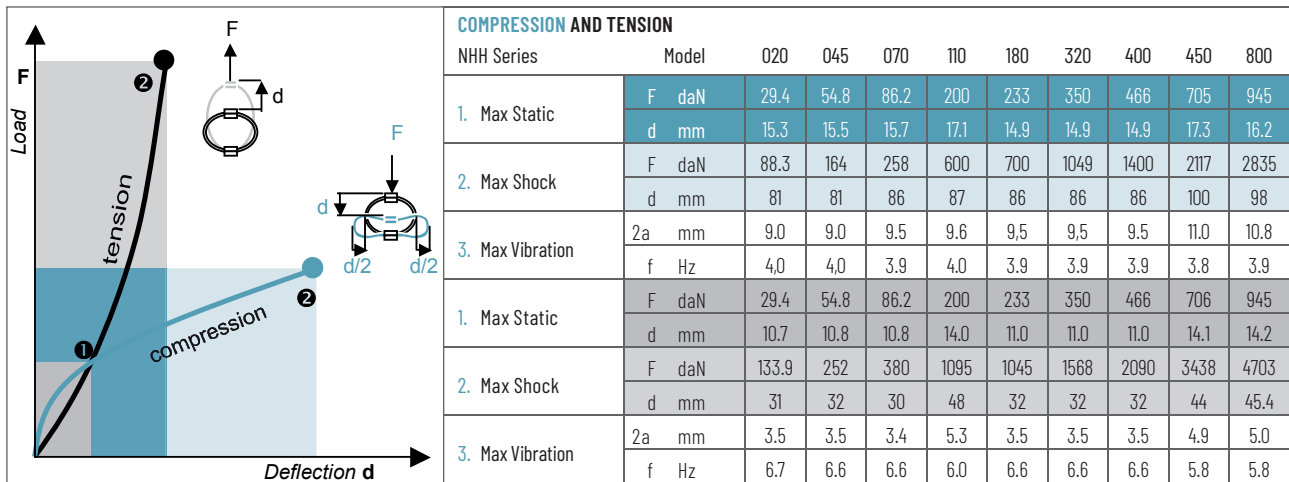

TYPICAL SHOCK / VIBRATION SPECIFICATIONS:

- Ground Forces** GAM EG13A, SEFT 001, MIL-STD-810, VG 95332.
- Air** AIR 7306, MIL-E-5400, MIL-C-172, MIL-STD-810.
- Marine** GAM EG13C, IT25-21/96-31/15-86, MIL-S-167, MIL-S-901, STANAG 042, BV 043.73, BV 044., BR3021, BR8470, NAV001.
- Others** GAM EMB1, GAM EMBT4, DEF STAN 07-55, IEC 571, FINABEL 2C.